

Tymbia Solutions, S.L.

Tel. 964 371 296 - comercial@carretillas-todoterreno.es - www.carretillas-todoterreno.es



**MAKE YOU
SAFER AND SMARTER**

**SCISSOR LIFTS
ZS1012/ZS1212**

ZS1012 / ZS1212

Models	ZS1012		ZS1212	
Measurements	US	Metric	US	Metric
A Working height maximum*	39 ft 3 in	11.96 m	45 ft 10 in	13.96 m
A Platform height maximum	32 ft 8 in	9.96 m	39 ft 3 in	11.96 m
B Length-stowed	8 ft 1 in	2.47 m	8 ft 1 in	2.47 m
C Width	3 ft 9 in	1.15 m	3 ft 9 in	1.15 m
D Height stowed fixed rails	8 ft 1 in	2.47 m	8 ft 6 in	2.60 m
Height stowed rails folded	6 ft	1.83 m	6 ft 5 in	1.95 m
E Platform length -Outside	7 ft 5 in	2.27 m	7 ft 5 in	2.27 m
F Slide-out platform extension deck	3 ft 3 in	1 m	3 ft 3 in	1 m
G Platform width - outside	3 ft 9 in	1.15 m	3 ft 9 in	1.15 m
H Wheelbase	6 ft 1 in	1.85 m	6 ft 1 in	1.85 m
I Ground clearance-center	4 in	0.10 m	4 in	0.10 m
J - with pothole guards deployed	0.80 in	0.02 m	0.80 in	0.02 m
Productivity				
Maximum Platform Occupancy **	2	2	1	1
Lift capacity	705 lbs	320 kg	705 lbs	320 kg
Lift capacity - extension deck	265 lbs	120 kg	265 lbs	120 kg
Drive height	full height			
Drive speed - stowed	2.2 mph	3.5 km/h	2 mph	3.2 km/h
Drive speed - raised	0.5 mph	0.8 km/h	0.5 mph	0.8 km/h
Gradeability - stowed***	25%		25%	
Turning radius - inside	0		0	
Turning radius - outside	7 ft 7 in	2.3 m	7 ft 7 in	2.3 m
Max. work angle of inclination	3° / 1.5°		3° / 1.5°	
Raise / lower speed (s)	58/48		70/68	
Controls	Proportional			
Drive	Dual front wheel			
Multiple disc brakes	Dual rear wheel			
Tires - solid non-marking	15 x 5 in	38 x 13 cm	15 x 5 in	38 x 13 cm
Power				
Drive Motor	3.3 kw		4.5 kw	
Power source	24 V DC (four 12 V 150 Ah batteries)			
Charger	90-240V 25 Amp			
Hydraulic system capacity	5.8 gal	22 L	5.8 gal	22 L
Weight****	6173 lbs	2800 kg	6878 lbs	3120 kg

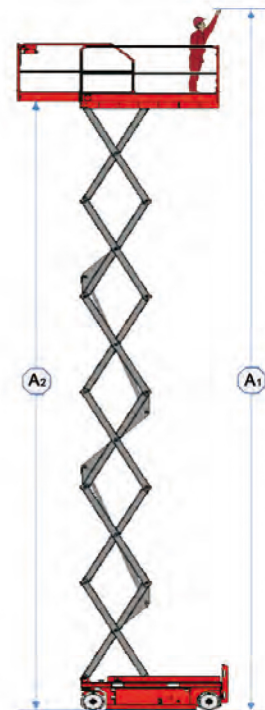
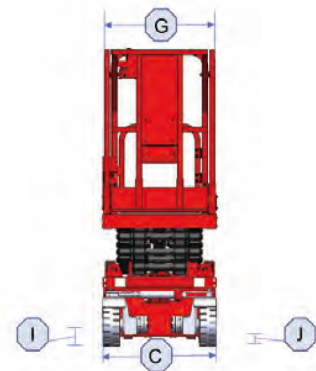
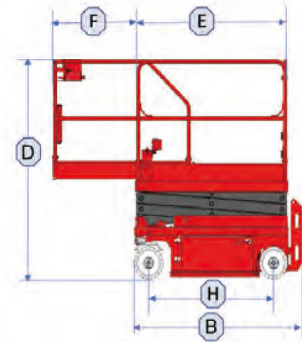

Standard Equipment

- Auto brake system
- Manual braking release
- Emergency lowering
- Lanyard attachment points
- Emergency stop at both platform and ground controls
- Hour meter
- Drive flashing beacons
- Motion alarm
- Electronic horn
- Descent alarm
- Descent protection
- Charging position regulation
- Tilt level sensor with audible alarm
- Overload protection system
- On-board diagnosis system
- Oil pipeline explosion-proof
- Pothole protection
- Safety brackets

Options & Accessories

- Folding rails on platform
- AC power to platform
- Airline to platform
- GPS module
- Obstacle alarm
- AGM maintenance free batteries
- Charging protection
- Platform flashing beacons